

# ANTELAO



**BFC srl**  
Via Martiri Delle Foibe, 15  
31015 Scomigo di  
Conegliano - TV - IT  
T. +39 0438 394979  
F. +39 0438 394587  
M. info@bfcsrl.it  
W. www.bfcsrl.it

I nostri canali social



BFCcoffemachinesofficial  
@bfccoffeemachines\_official

## STANDARD FEATURES:

- New steam nozzles with anti-scald system to facilitate use.
- Competition shower with micropores coated with the application of nanotechnology, a high quality NanoQuartz coating that improves the non-stick properties of this shower and allows even more homogeneous water distribution.
- A TFT colour touch-screen display that allows setting and monitoring of the dispensing parameters of each coffee and of each blend through intuitive icons ensuring an excellent result.
- Side courtesy lights and sub-group lights that allow uniform work space lighting.
- Insulated thermosiphon circuit copper boilers to reduce energy consumption and to improve thermal stability with respect to traditional coffee machines. In addition, thanks to the ECO mode an additional energy saving is guaranteed of 1.3 kW in the 2 groups and 2.6 kW in the 3 groups model. (ECO mode available only for electronic model).
- Raised gratings for maximum versatility in all preparations.
- Heat-balancing units.
- Thermoregulated electronic cup-warmer.

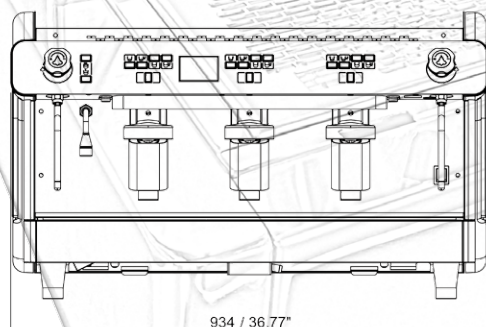
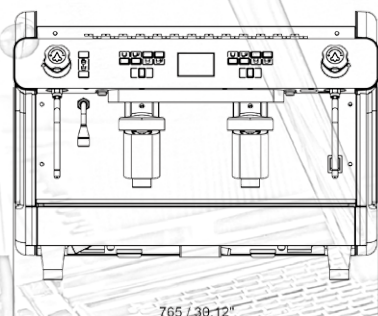
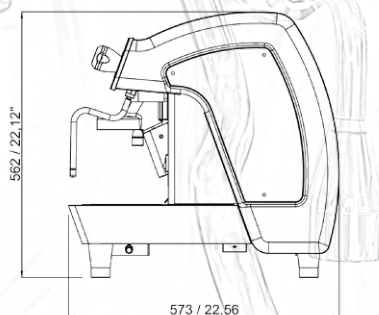

### GRUPPI / GROUPS / GRUPPEN / GROUPES / GRUPOS \*

Peso Kg/lbs - Net weight - Nettogewicht - Poids net - Peso

Caldaia lt./US GAL - Boiler - Kassel - Chaudière - Caldera

Caldaia T.C.I gruppo lt./US GAL - Boiler T.C.I. group - Kassel T.C.I. groupe Chaudière T.C.I. groupe - Caldera T.C.I. grupo

Watt (220 ÷ 240)

Volt

Portafiltri - Filter holders - Filter Träger - Porte-filtre - Portafiltro

	2	2 T.C.I.	3	3 T.C.I.
	(14 lt.)	(11 lt.)	(21 lt.)	(14 lt.)
	84 / 185	94 / 207	102 / 225	115 / 254
	14 / 3,7	11 / 2,91	21 / 5,5	14 / 3,7
		2 x 0,8 lt. 2 x 0,21 gal.		3 x 0,8 lt. 3 x 0,21 gal.
	3700 4360	7300 8660	5450 6450	8600 10210
	230 / 240 / 400			
	3	3	4	4